

## Features

- Input Voltage Range is from 2.7 to 5.5V
- Dropout Voltage 400mV at 300mA Output Current
- Guaranteed 300mA Output Current
- Internal Ron = 1.5Ω PMOS draws no Base Current
- Low Quiescent Current 50µA
- Output Voltage: 1.5V/1.8V/2.0V/2.5V/2.8V/2.9V/3.0V/3.3V/ 3.5V; Accuracy 2%
- Active Low Shutdown Function (EN pin)
- Fast Transient Response
- Good Load Regulation
- Current Limit and Thermal Shutdown Protection
- Short Circuit Current Fold-Back
- Lead Free package: SOT25
- SOT25: Available in "Green" Molding Compound (No Br, Sb)
- Lead Free Finish/RoHS Compliant for Lead Free products (Note 1)

## General Description

The AP131 is a 300mA, fixed output voltage, low dropout linear regulator. The Device included pass element, error amplifier, band-gap, current limit and thermal shutdown circuitry. The device is ON when the EN pin is set to logic high level.

The characteristics of low dropout voltage and less quiescent current make it good for some critical current applications, for example, some battery powered devices. The typical quiescent current is approximately 50µA from zero to maximum load. Due to the internal flexible design, it results in extensively fixed output voltage versions and makes it convenient to use for applications. Built-in current-limit and thermal-shutdown functions prevent any fault condition from IC damage. An external capacitor can be connected to the BP pin and reduce the output noise.

## Applications

- Battery Powered Device
- Wireless Communication
- CD-ROM, DVD, and LAN Card
- PC Peripheral

## Ordering Information

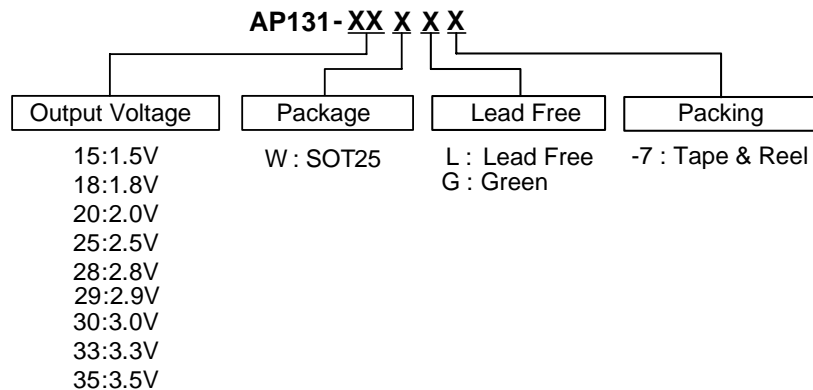

Note: 1. RoHS revision 13.2.2003. Glass and High Temperature Solder Exemptions Applied, see *EU Directive Annex Notes 5 and 7*.

Device	Package Code	Packaging (Note 2)	7" Tape and Reel	
			Quantity	Part Number Suffix
AP131-XXW	W	SOT25	3000/Tape & Reel	-7

Note: 2. Pad layout as shown on Diodes Inc. suggested pad layout document AP02001, which can be found on our website at <http://www.diodes.com/datasheets/ap02001.pdf>.

**Pin Assignment**

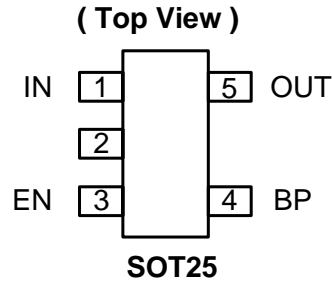

**Pin Description**

Name	Description
IN	Input Voltage
GND	Ground
EN	Enable Pin
BP	Band-gap
OUT	Output Voltage

**Block Diagram**

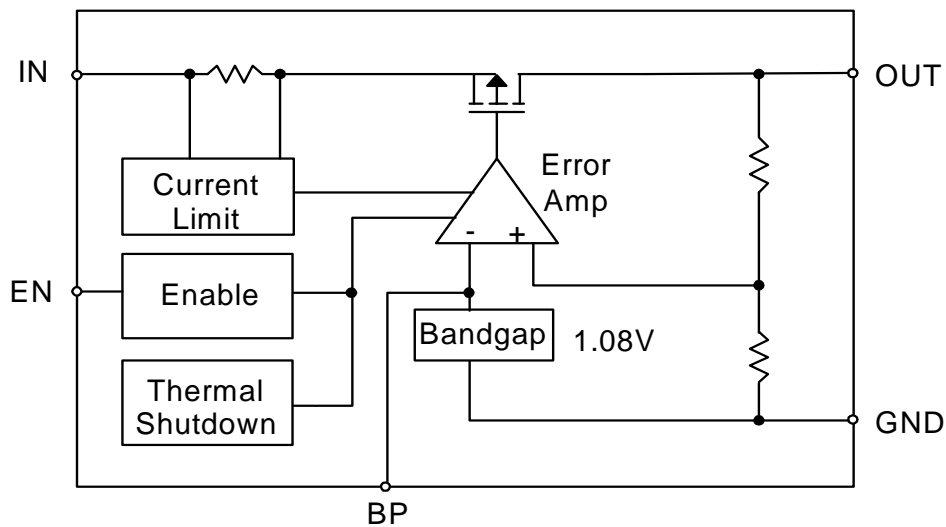

---

**Absolute Maximum Ratings**

---

Symbol	Parameter	Rating	Unit
$V_{CC}$	Input Voltage	+6	V
$T_{OP}$	Operating Junction Temperature Range	-40 to +125	°C
$T_{ST}$	Storage Temperature Range	-65 to +150	°C
$P_D$	Power Dissipation, $P_D$ @ $T_A = 25^\circ\text{C}$	SOT25 250	mW

---

**Recommended Operating Conditions**

---

Symbol	Parameter	Min	Max	Unit
$V_{IN}$	Input Voltage	2.7	5.5	V
$I_{OUT}$	Output Current	0	300	mA
$T_A$	Operating Ambient Temperature	-40	85	°C

**Electrical Characteristics**
 $T_A = 25^\circ\text{C}$ ,  $C_{IN} = 1\mu\text{F}$ ,  $C_{OUT} = 10\mu\text{F}$ , unless otherwise specified.

Symbol	Parameter	Conditions	Min.	Typ.	Max.	Unit
$V_{DROP}$	Dropout Voltage (Note 5)	$I_L = 300\text{mA}$	-	400	500	mV
$I_{LIMIT}$	Current Limit (Note 6)	$V_{IN} = 5\text{V}$ , $V_{OUT} = 0\text{V}$	350	450	-	mA
$I_{short}$	Short Circuit Current	$V_{OUT} < 1.05\text{V}$	-	150	300	mA
$\Delta V_{LINE}$	Line Regulation	$I_{OUT} = 1\text{mA}$ , $V_{IN} = (V_{OUT} + 1\text{V})$ to $5.5\text{V}$	-	0.1	0.3	%/V
$\Delta V_{LOAD}$	Load Regulation (Note 7)	$I_L = 1\sim 300\text{mA}$ , $V_{IN} = 5\text{V}$	-	30	35	mV
$\Delta V_{OUT}$	Output Voltage Accuracy	$I_L = 1\text{mA}$ , $V_{IN} = 5\text{V}$	-2	-	+2	%
	Output Voltage Temperature Coefficient (Note 8)		-	50	150	PPM/ $^\circ\text{C}$
PSRR	Ripple Rejection	$F = 100\text{Hz}$ , $C_{IN} = 1\mu\text{F}$ , $C_O = 10\mu\text{F}$ , $I_L = 100\text{mA}$	-	60	-	dB
$I_{SB}$	Standby Current	$I_L = 0\text{mA}$ , $V_{IN} = 5\text{V}$ , $EN = 0\text{V}$	-	-	5	$\mu\text{A}$
$I_Q$	Quiescent Current	$I_L = 0\text{mA}$ , $V_{IN} = 5\text{V}$ , $EN = 5\text{V}$	-	50	100	$\mu\text{A}$
$I_{EN}$	Enable Pin Current		-	-	< 0.1	$\mu\text{A}$
$V_{ENON}$	Enable Pin Voltage	Output ON	1.5	-	$V_{IN}$	V
$V_{ENOFF}$		Output OFF	0	-	0.8	V
$T_{DELAY}$	Enable Delay Time	$C_{BP} = 0.1\mu\text{F}$ , $C_{OUT} = 1\mu\text{F}$ , $I_{OUT} = 30\text{mA}$	-	8	-	$\mu\text{S}$
$\theta_{JA}$	Thermal Resistance Junction-to-Ambient	SOT25 (Note 9)		163		$^\circ\text{C/W}$
$\theta_{JC}$	Thermal Resistance Junction-to-Case	SOT25 (Note 9)		53		$^\circ\text{C/W}$

- Note: 5. Dropout voltage is defined as the input to output differential voltage. Dropout is measured at constant junction temperature by using pulsed ON time, and the criterion is  $V_{OUT}$  inside target value  $\pm 2\%$ . This test is skipped at the condition of  $V_{IN} < 3\text{V}$ .  
6. Current limit is measured at constant junction temperature by using pulsed testing with a low ON time.  
7. Regulation is measured at constant junction temperature by using pulsed testing with a low ON time.  
8. Guaranteed by design.  
9. Test conditions for SOT25: Device mounted on FR-4 substrate PC board, 2oz copper, with minimum recommended pad layout.

**Typical Characteristics**

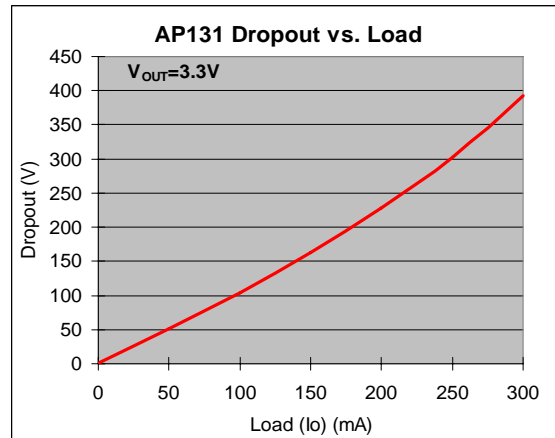
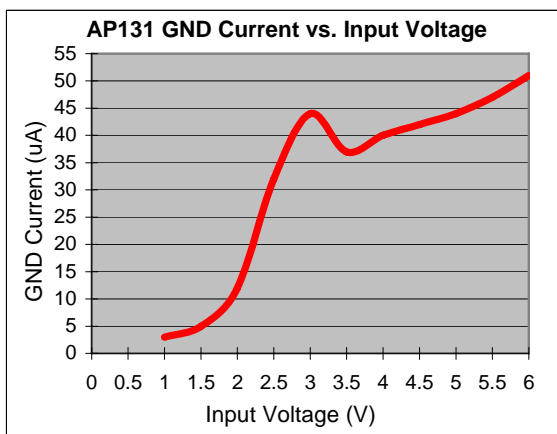
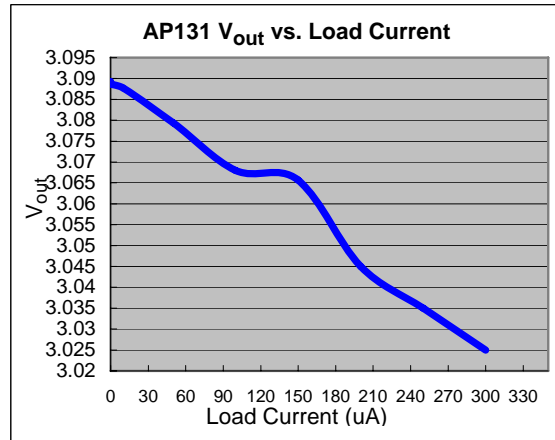
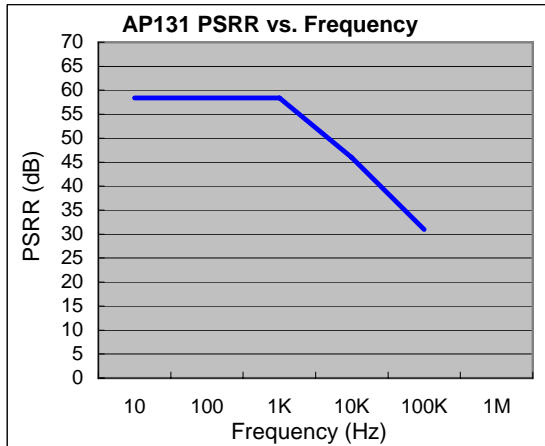

**Typical Application Circuit**

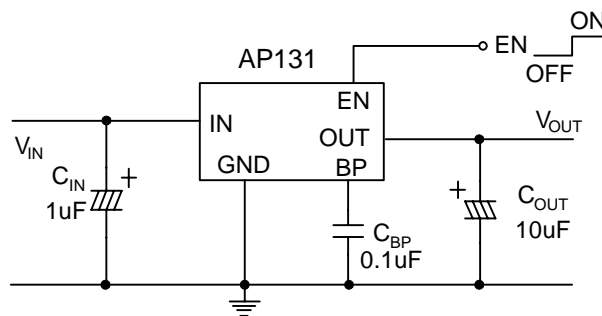

**Marking Information**

( Top View )

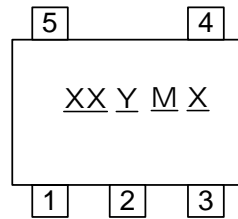

XX : Identification code  
 Y : Year 0~9  
 M : Month A~L  
 X : L : Lead Free Package  
       G : Green Package

**SOT25**

Device	Identification Code
AP131-15W	DA
AP131-18W	DD
AP131-20W	DF
AP131-25W	DK
AP131-28W	DN
AP131-29W	DO
AP131-30W	DP
AP131-33W	DS
AP131-35W	DU

**Package Information (All Dimensions in mm)**

Package Type: SOT25

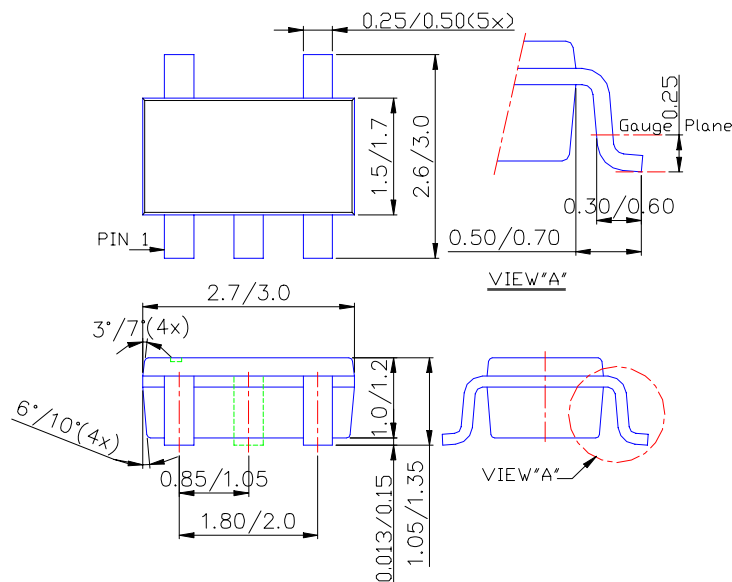

**IMPORTANT NOTICE**

Diodes Incorporated and its subsidiaries reserve the right to make modifications, enhancements, improvements, corrections or other changes without further notice to any product herein. Diodes Incorporated does not assume any liability arising out of the application or use of any product described herein; neither does it convey any license under its patent rights, nor the rights of others. The user of products in such applications shall assume all risks of such use and will agree to hold Diodes Incorporated and all the companies whose products are represented on our website, harmless against all damages.

**LIFE SUPPORT**

Diodes Incorporated products are not authorized for use as critical components in life support devices or systems without the expressed written approval of the President of Diodes Incorporated.